

Kawasaki Robot Palletizing robots

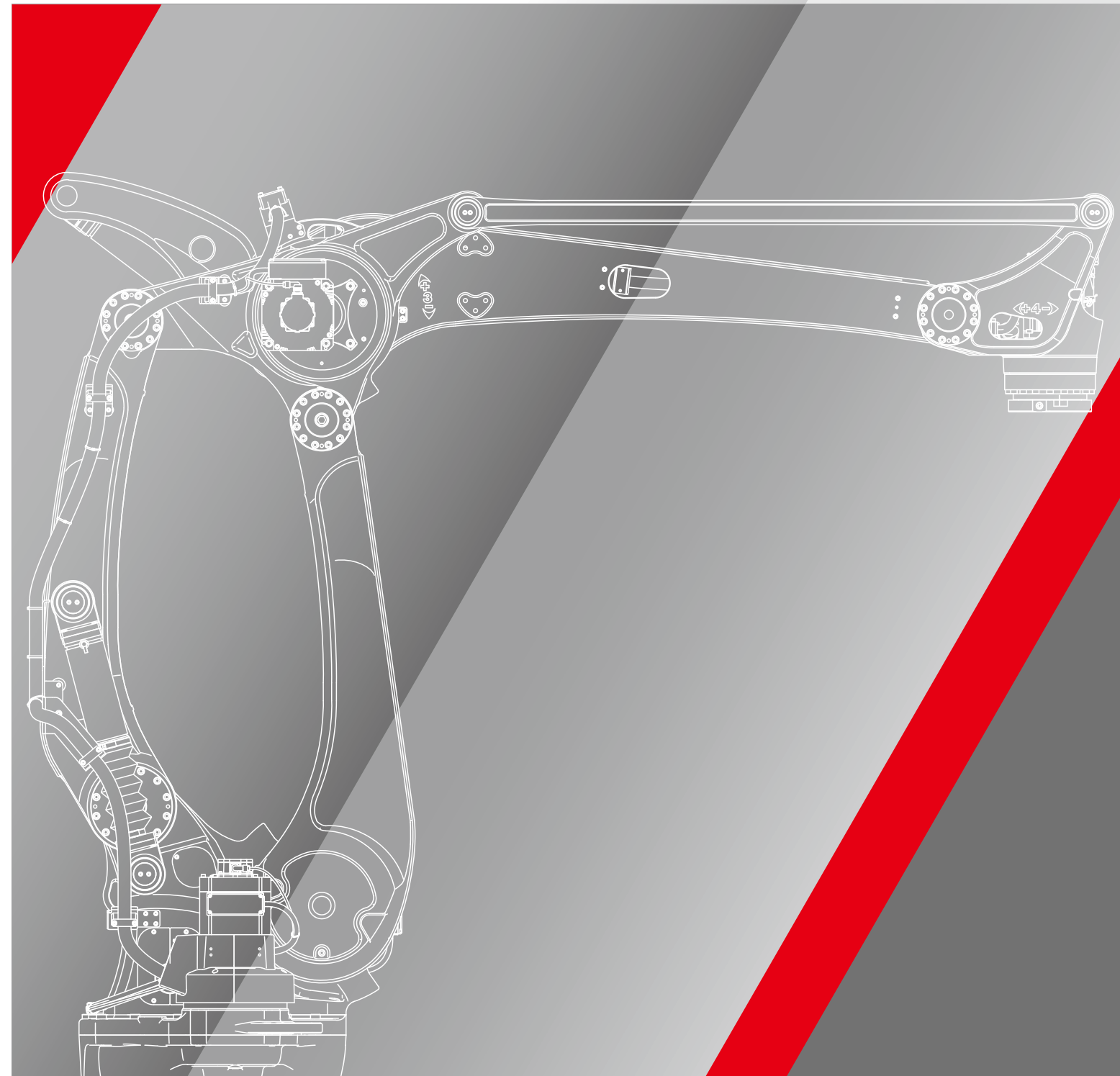

Kawasaki Heavy Industries, Ltd.

Robot Business Division

Tokyo Head Office/Robot Division

1-14-5, Kaigan, Minato-ku, Tokyo 105-8315, Japan
Phone: +81-3-3435-2501 Fax: +81-3-3437-9880

Akashi Works/Robot Division

1-1, Kawasaki-cho, Akashi, Hyogo 673-8666, Japan
Phone: +81-78-921-2946 Fax: +81-78-923-6548

Global Network

Kawasaki Robotics (USA), Inc.

28140 Lakeview Drive, Wixom, MI 48393, U.S.A.
Phone: +1-248-446-4100 Fax: +1-248-446-4200

Kawasaki Robotics (UK) Ltd.

Unit 4 Easter Court, Europa Boulevard, Westbrook Warrington
Cheshire, WA5 7ZB, United Kingdom
Phone: +44-1925-71-3000 Fax: +44-1925-71-3001

Kawasaki Robotics GmbH

Im Taubental 32, 41468 Neuss, Germany
Phone: +49-2131-34260 Fax: +49-2131-3426-22

Kawasaki Robotics Korea, Ltd.

43, Namdong-daero 215beon-gil, Namdong-gu, Incheon, 21633,
Korea
Phone: +82-32-821-6941 Fax: +82-32-821-6947

Kawasaki Robotics (Tianjin) Co., Ltd.

1-2/F, Building 6, No.19 Xinhuan Road, TEDA, China
Phone: +86-22-5983-1888 Fax: +86-22-5983-1889

Kawasaki Motors Enterprise (Thailand) Co., Ltd.

(Rayong Robot Center)
119/10 Moo 4 T.Pluak Daeng, A.Pluak Daeng, Rayong 21140
Thailand
Phone: +66-38-955-040-58 Fax: +66-38-955-145

<https://robotics.kawasaki.com/>

Kawasaki Robot

CAUTIONS TO BE TAKEN TO ENSURE SAFETY

- For those persons involved with the operation / service of your system, including Kawasaki Robot, they must strictly observe all safety regulations at all times. They should carefully read the Manuals and other related safety documents.
- Products described in this catalogue are general industrial robots. Therefore, if a customer wishes to use the Robot for special purposes, which might endanger operators or if the Robot has any problems, please contact us. We will be pleased to help you.
- Be careful as Photographs illustrated in this catalogue are frequently taken after removing safety fences and other safety devices stipulated in the safety regulations from the Robot operation system.



ISO certified in Akashi Works.

Kawasaki's high-speed palletizing robots meet the demands for flexibility and speed.

Standard specifications

In today's highly competitive marketplace, meeting the demand for just-in-time deliveries, flexible packaging, the freshest products, or the highest production line efficiencies can be crucial to a company's success. Efforts to meet these demands have led to the development of automation systems for the end-of-line and distribution processes of palletizing and depalletizing. Kawasaki's robotic palletizing solutions provide the pallet pattern flexibility, tooling flexibility, and cycle times needed to deal with multi-variety and small-batch production, and reduce process change costs.

Kawasaki Robotics offers two different lines of palletizing robots with a wide range of payload options to suit most needs, including model RD80N with a maximum payload of 80 kg and models CP180L/300L/500L/700L with maximum payloads of 180/300/500/700 kg. Each has industry leading reach, speed and quality to deliver high-performance automation technology for most any palletizing application.

Kawasaki can provide a solution to give your production line the palletizing flexibility and product rate it needs to compete in today's economy.

		RD080N	CP180L	CP300L	CP500L	CP700L
Arm type		Articulated type				
Degrees of freedom (axes)		5	4			
Max. payload (kg)		80	180	300	500	700
Max. stroke (°)	Arm rotation (JT1)	±180	±160			
	Arm out-in (JT2)	+140 - -105	+95 - -46			
	Arm up-down (JT3)	+40 - -205	+15 - -110			
	Wrist swivel (JT4)	±360	±360			
	Wrist compensation (JT5)	±10 *4	-			
Max. speed (°/s)	Arm rotation (JT1)	180	140 *5	115 *6	85	75
	Arm out-in (JT2)	180	125 *5	100 *6	80	65
	Arm up-down (JT3)	175	130 *5	100 *6	80	65
	Wrist swivel (JT4)	360	400 *5	250 *6	180	170
Working area (mm)	Width	1,100	1,800			
	Depth	1,100	1,600			
	Height	2,062.3	2,200			
Moment of inertia (kg·m ²)		13.7	50 *5	100 *6	250	500
Palletizing capacity *1 (cycle/hour)		900	2,050 *5	1,700 *6	1,000	900
Positional repeatability *2 (mm)		±0.07	±0.5			
Mass (kg)		540	1,600		1,650	
Power requirements *3 (kVA)		4.5	12			
Controller		E03				

*1: Motion pattern (400 mm up, 2,000 mm horizontal, 400 mm down in a to-and-fro motion) *2: conforms to ISO9283
 *3: depends on the payload condition and motion patterns *4: operating angle of the JT5 is ±10 degrees perpendicular to the ground.
 *5: In case of 130 kg payload or smaller *6: In case of 250 kg payload or smaller



RD080N



CP180L/300L



CP500L



CP700L

Features

Palletizing capacity worthy of our high-speed age

Kawasaki palletizing robots deliver the high-speed operation needed for distribution. Based on a robot stroke of 400 mm upward-downward and 2,000 mm in the left-right direction, the RD080N can perform 900 cycles per hour with loads of 80 kg, and the CP180L achieves an industry leading 2,050 cycles per hour with loads of 130 kg.

Compact applications

The Kawasaki RD080N is designed specifically for applications where a compact, high-speed, palletizing robot is required. Despite its slim space saving design, the RD80N can manipulate loads up to 80 kg and create pallet stacks over 2 meters tall.

Large work envelope and high payload capacity

With the large vertical reach of 3,256 mm, the CP series robots are ideal for tall pallet stacks and multi-lane applications. The extra-long horizontal reach of 3,255 mm allows the robot to cover up to four pallets. The high payload capacity CP series robots can handle up to 700 kg. This allows for multiple product picks and complete pallet layer handling, resulting in fewer cycles per completed pallet.

Easy-to-use palletizing software K-SPARC

Available as an option, Kawasaki's K-SPARC palletizing software enables users to quickly and easily simulate layout planning and operations, as well as create robot operation programs on a computer.

Space and energy saving

The CP series E03 controller is only 25% of the standard palletizing* controller size (41% with transformer unit) and fits under conveyors and other equipment. The E03 controller generates electric power while in a deceleration mode, reducing energy consumption and minimizing CO₂ emissions.

* in case of E4X

Electricity Regeneration Function

Conventional controller

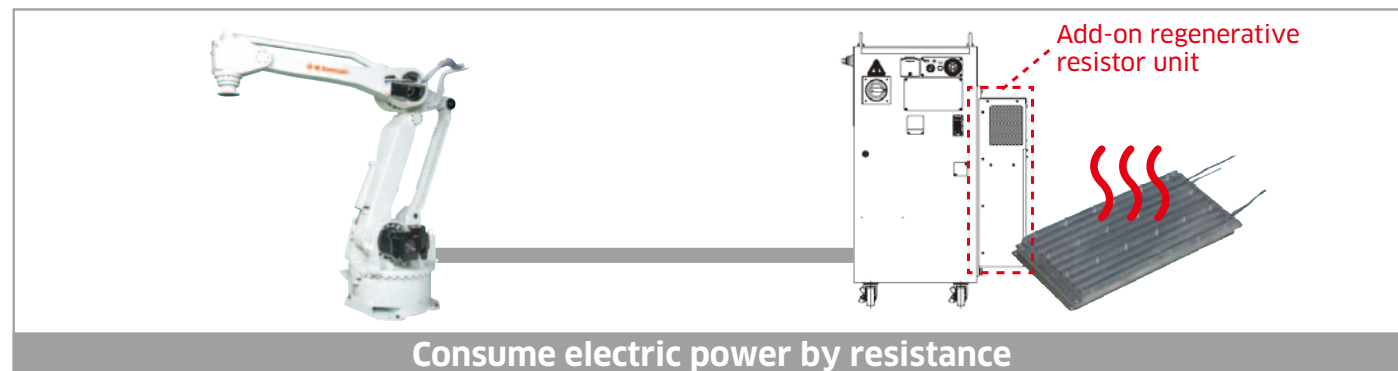

E03 Controller

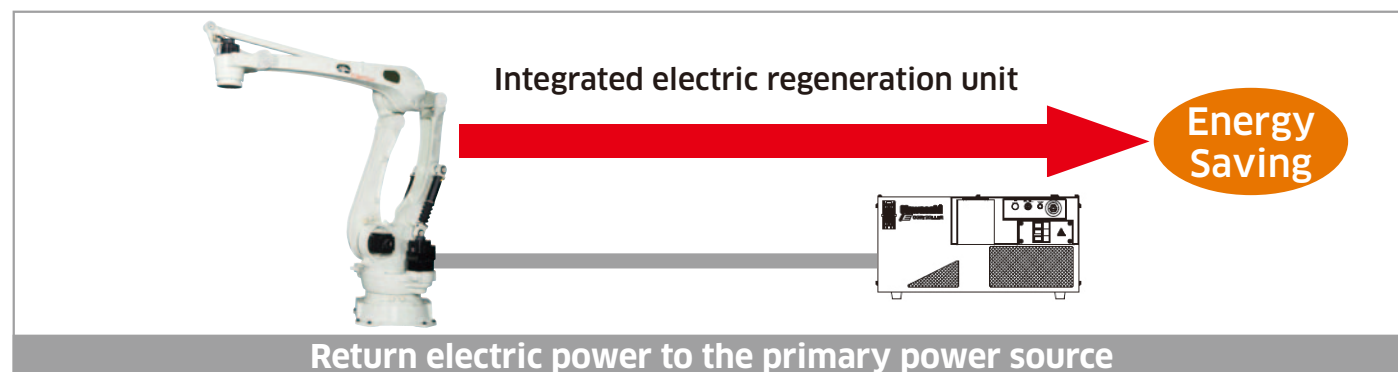

Palletizing cells

Kawasaki provides system configurations perfectly adapted to your needs.

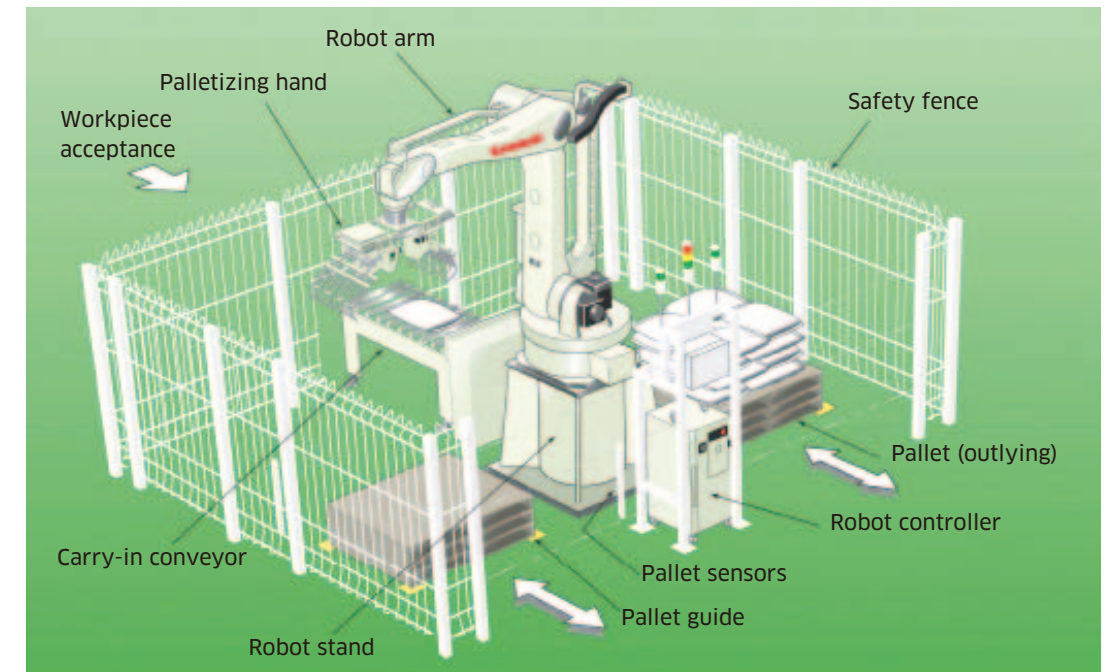

Sample layout for palletizing cells

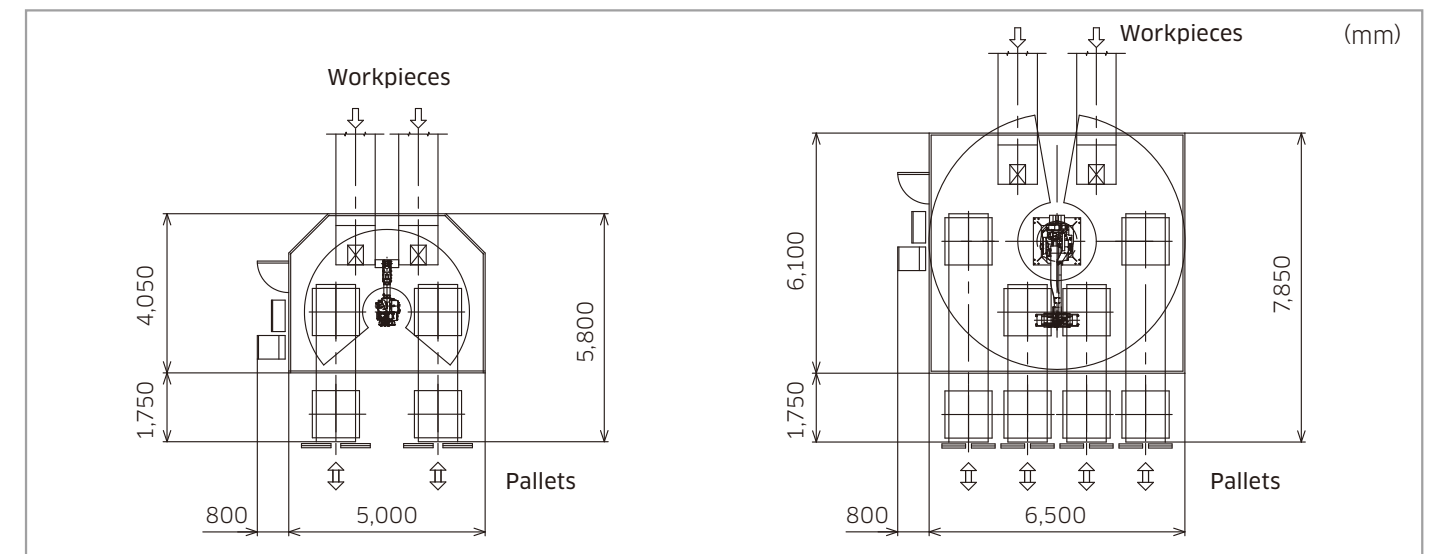

Sample of palletizing cells

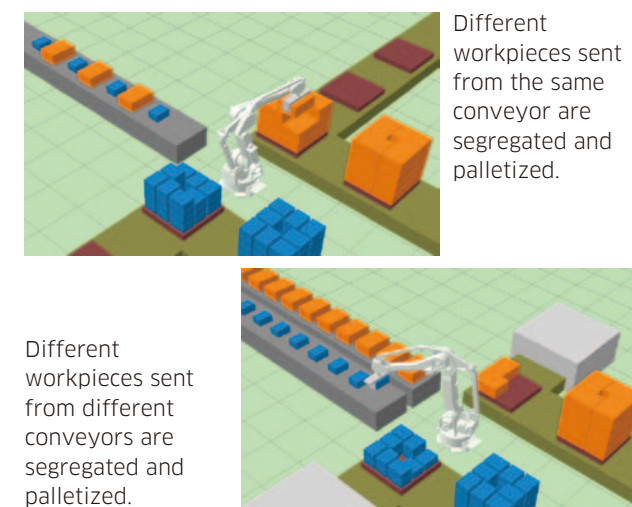

System configuration example

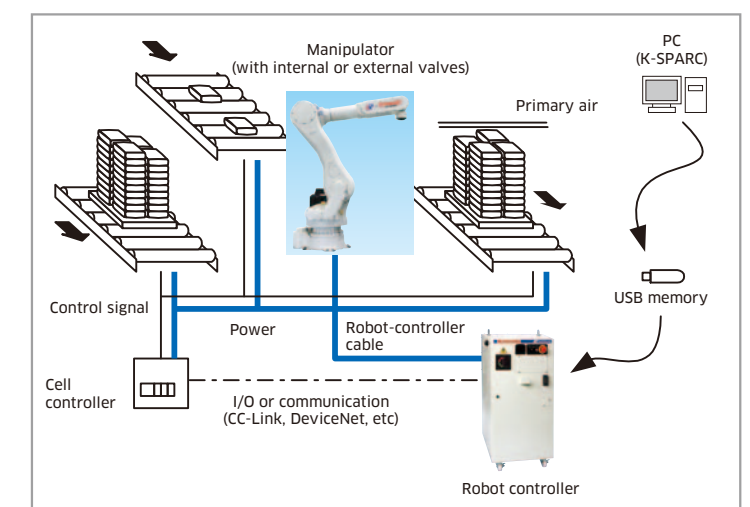

3D Vision system (option)



Depalletizing of cardboard and paper bags

Specifications

Measuring range	1,100mm×1,100mm
Distance to object	1,900mm - 3,700mm (distance from top of workpiece)
Processing speed	less than 1 second (processing time fluctuates depending on the object)
Resolution of Z	±3.5 to ±12mm (varies with distance to the object)
Resolution of XY	±1.2mm to ±2.5mm (varies with distance to the object)

Features

- Registration of the target workpiece is not necessary. Automatic recognition is possible with only dimensional information of the workpiece from outside.

- Initial adjustment work is drastically reduced thanks to suitable robot application packages.
- High-speed recognition is possible using dedicated vision equipment.

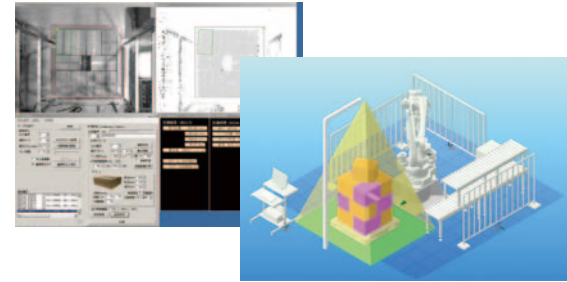

Easy-to-use palletizing software (option)



You can build an advanced and flexible robot safety system according to the motion condition by monitoring the movements of the robot.

Supervise Safety Smart



- Save Space by limiting the range of robot movements
- Safety function can be switched according to the state of safety signal input
- IEC61508 (SIL2) and ISO13849-1 (PLd/category 3) certification

Save space

You can reduce the size of the safety fence area by limiting the range of robot movements to the minimum.

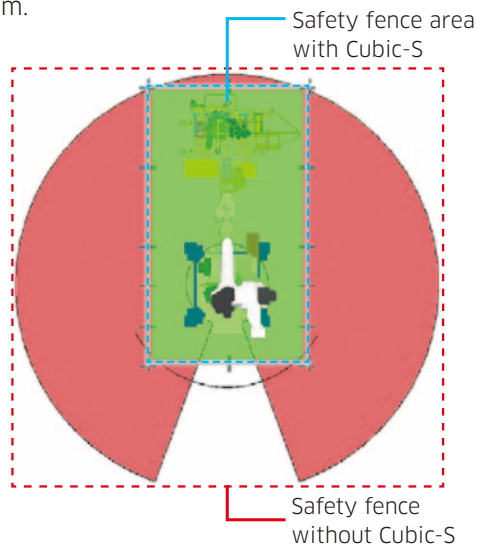

Reduced safety fence area

Transporting workpieces during robot motion

You can limit the range of robot movements according to the human work area.

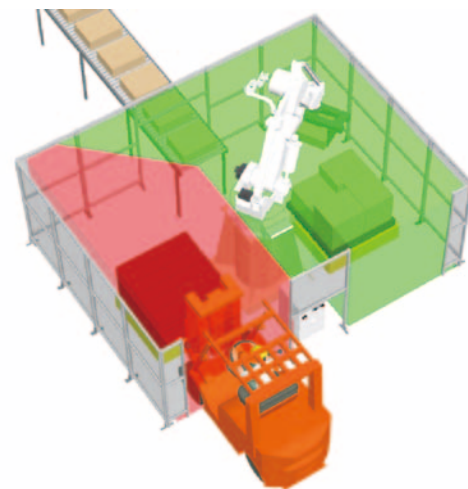

Reduced cycle time

Item	Specification
Safety performance	IEC61508 (SIL2) ISO13849-1 (PLd/category3)
Monitoring the number of joints	Maximum 9 joints
Safety function	Motion area monitoring, Joint monitoring, Speed monitoring, Stand still monitoring, Tool orientation monitoring, Protective stop, Emergency stop, Safety status output
Safety input and output	Dual channel safety input 8CH Dual channel safety output 8CH * It is possible to allocate Safety Status Output Signals and Safety Input Signals of each Safety functions

Simple palletizing software (option)



This software lets you configure the pick and place positions of the workpieces by robots and register workpieces, pallets, and stacking patterns displayed on your computer's screen. It also allows you to easily create robot operation programs.

This optional software is one of the application programs built on K-ROSET, Kawasaki's offline teaching software.

OS environment: Windows 7/10 (x86, x64*)
*On a 64-bit computer, it runs in the 32-bit compatible mode.

Easy setup by layout selection

Support for up to three pick positions and four place positions of workpieces by robots. Simply select a layout and enter a distance!

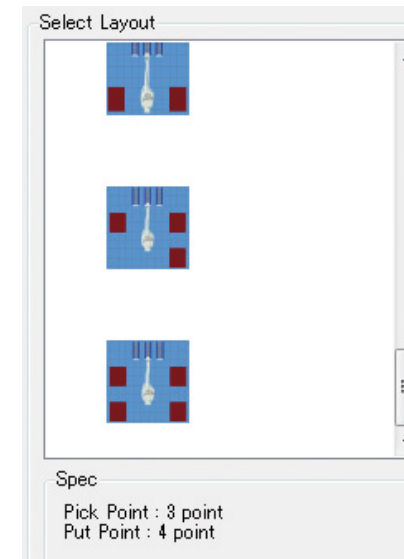

K-ROSET functions can be used

With K-ROSET, users can specify the layout by analyzing the installation positions automatically according to the robot types and place positions. You can also check for interference and perform cycle time analysis.

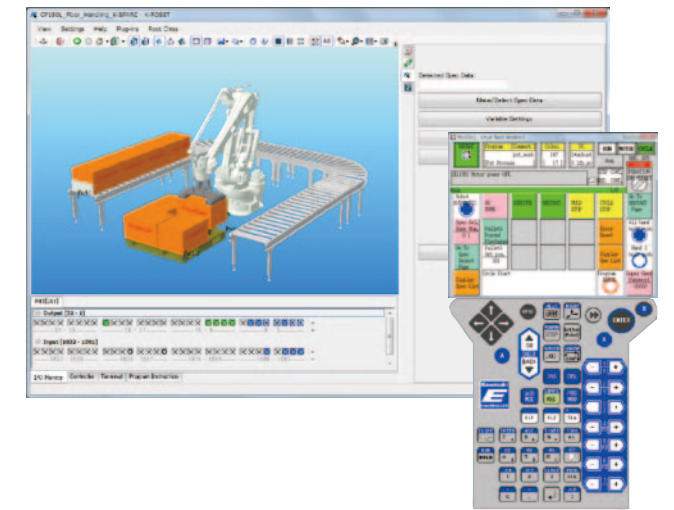

Easy registration of item types

Item types are registered simply by entering data on your computer for workpieces, pallets, and stacking patterns.

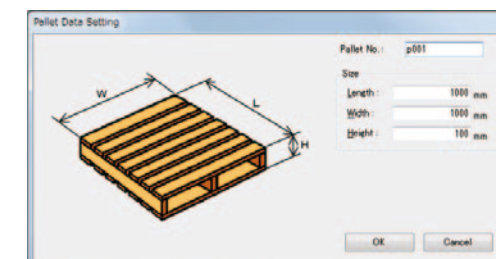
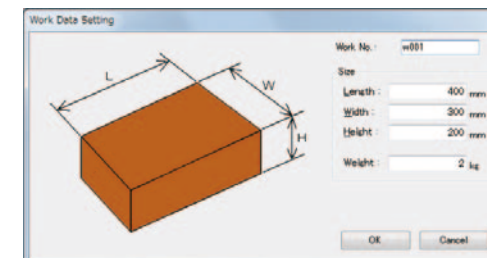

Support for many kinds of stacking patterns

Approximately 200 types of base patterns can be configured for each stage. The place position of workpieces can be specified. Gaps can also be adjusted.

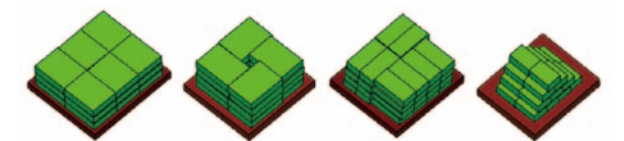
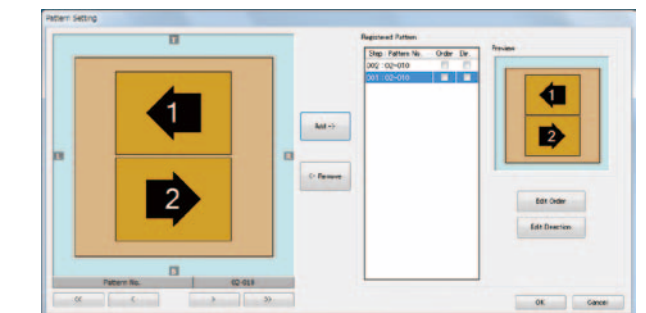

RD080N

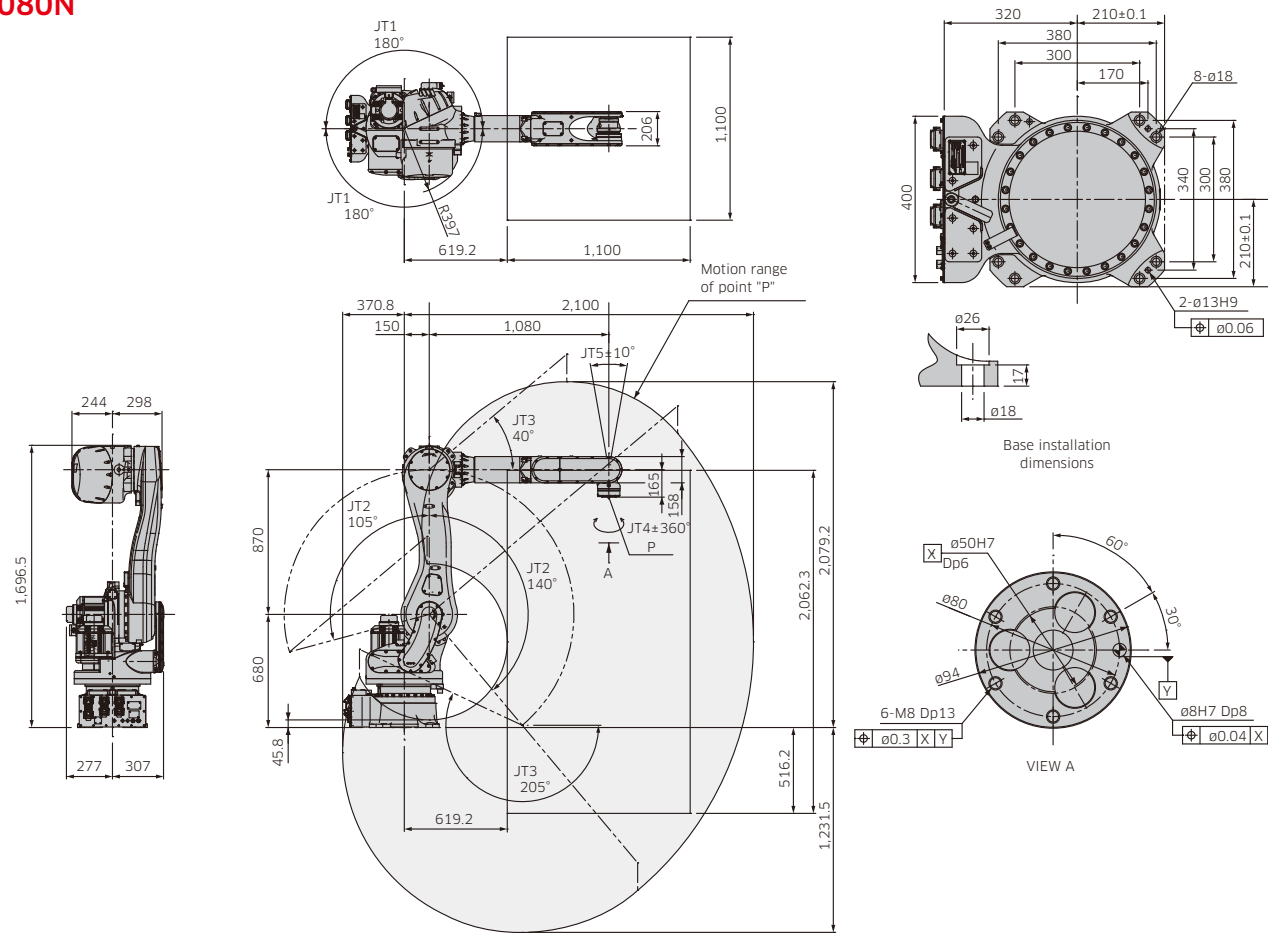

(mm)

CP500L

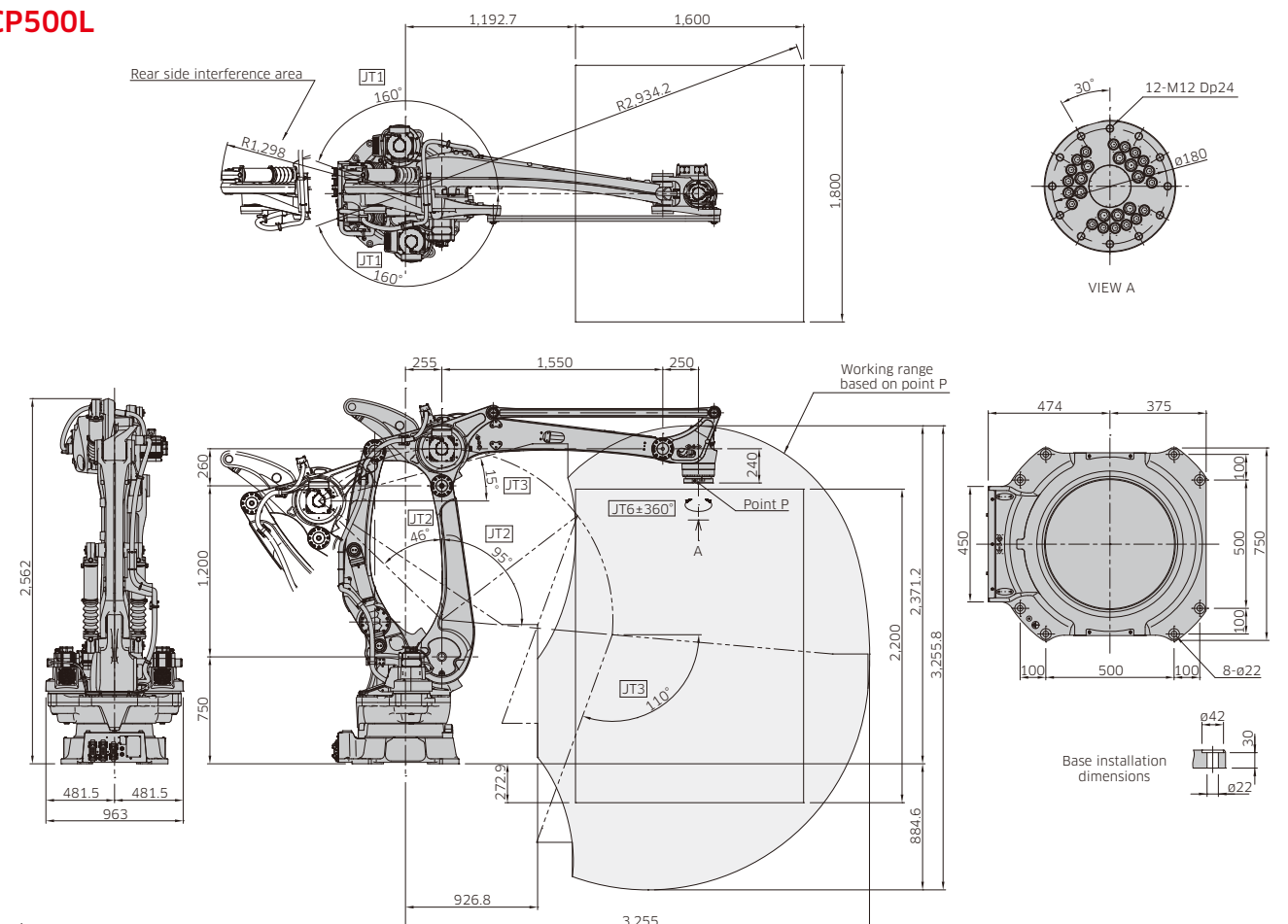

(mm)

CP180L/300L

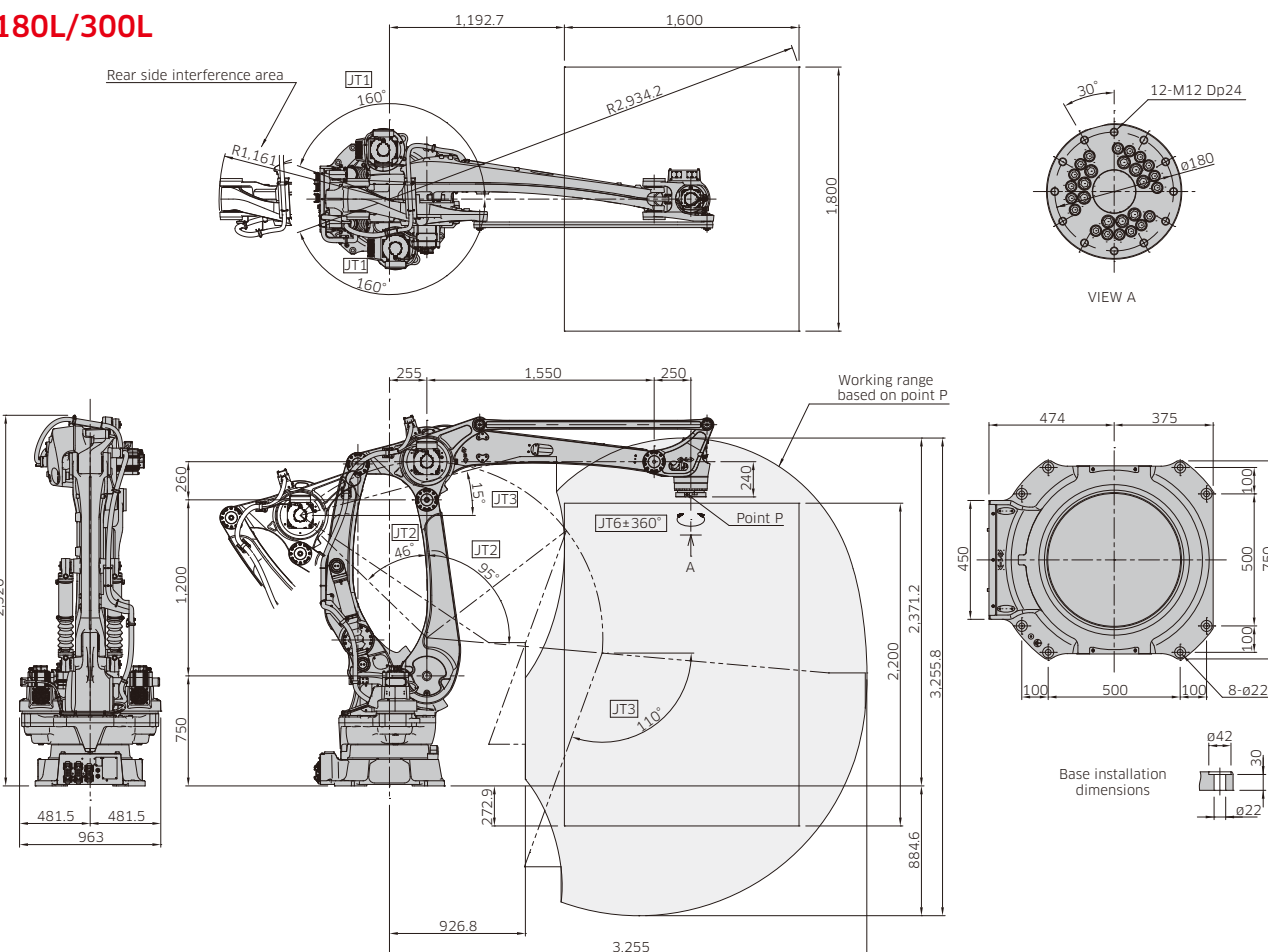

(mm)

CP700L

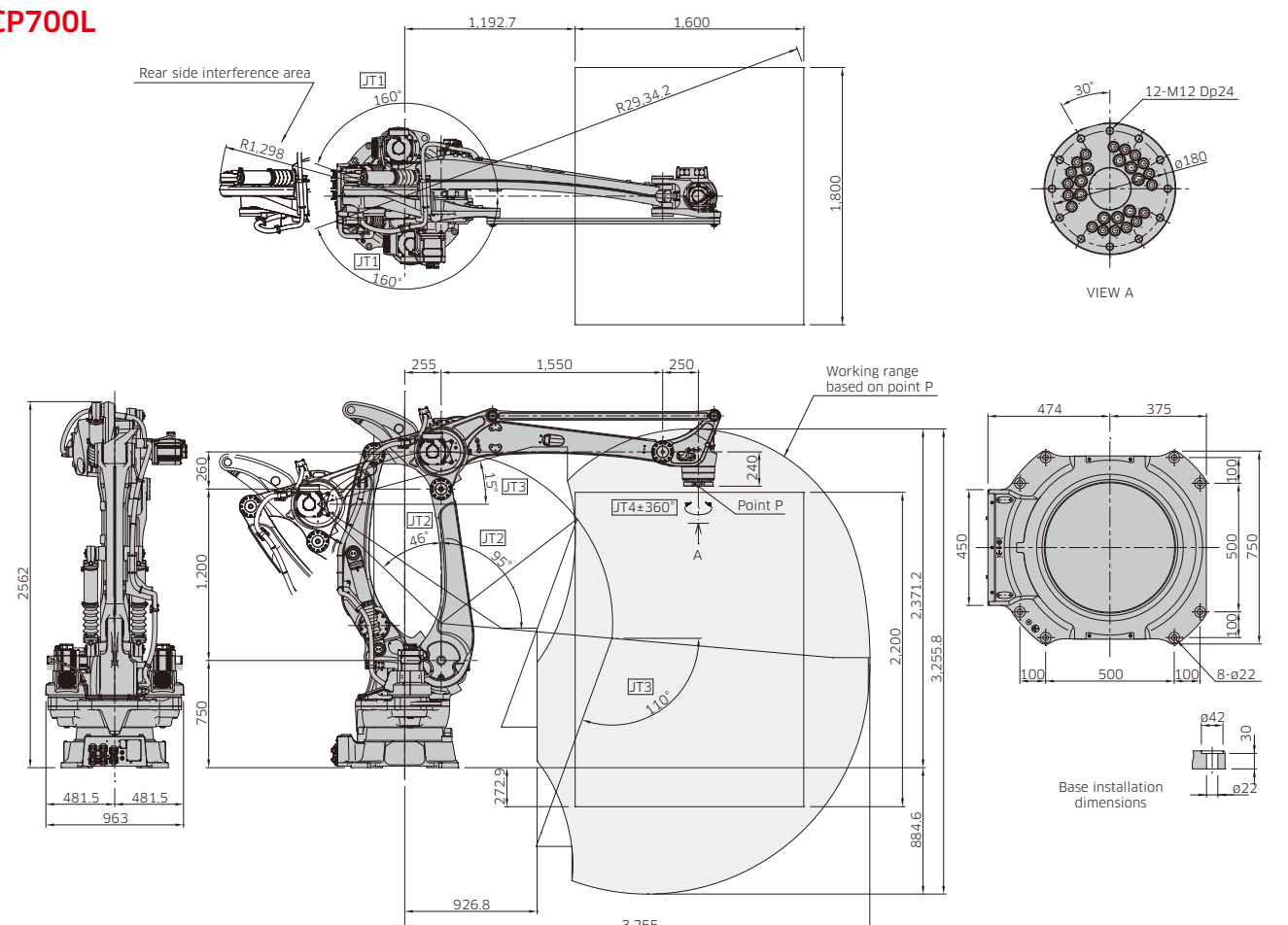

(mm)

E series

The E Controller combines high performance, unprecedented reliability, a host of integrated features and simple operation, all in a compact design.



*Option

Features

Compact

The E03 controller for CP series palletizing robots has far less volume. You can use it in an upright-position or in a stacked installation to reduce the footprint of this controller.

User-friendly operation

The easy-to-use teach pendant now incorporates motor power and cycle start at your fingertips. Multiple information screens can be displayed simultaneously. The intuitive teaching interface is simple to use.

Programming ease & flexibility

A rich set of programming functions come standard with the E Controller to support a wide range of applications. Functions can be combined and easily configured within a system to suit a particular application. Also, the powerful Kawasaki AS Programming Language provides sophisticated robot motion and sequence controls.

Advanced technologies

The enhanced CPU capacity allows for more accurate trajectory control, faster program execution, and quicker loading and saving of files. In addition, memory has been expanded to meet the need for higher program storage capacity. The controller comes equipped with a USB port for external storage devices.

Easy maintenance

Modular components with limited cables translate into easy diagnostics and maintenance. A host of maintenance functions are available, including self-diagnostics on hardware and application errors to minimize troubleshooting and reduce MTTR (Mean Time To Repair). Remote diagnostics via the web server function enables service support from anywhere in the world.

Space and energy saving

The CP series E03 controller is only 25% of the standard palletizing controller size (41% with transformer unit) and fits under conveyors and other equipment. The E03 controller generates electric power while in a deceleration mode, reducing energy consumption and minimizing CO2 emissions.

Specifications

		Standard	Option
Dimensions (mm)		W550×D580×H278	Transformer unit: W580×D580×H178
Structure		Enclosed structure / Indirect cooling system	
Number of controlled axes		5	6
Drive system		Full digital servo system	
Coordinate systems		Joint, Base, Tool	Fixed tool point
Types of motion control		Joint/Linear/Circular Interpolated motion	
Programming		Point to point teaching or language based programming	
Memory capacity (MB)		8	
General purpose signals	External operation	Motor power off, Hold	
	Input (Channels)	32	Max. 96
	Output (Channels)	32	Max. 96
Operation panel		E-Stop switch, teach/repeat switch, control power light	Fast check mode switch
Cable length	Teach pendant (m)	5	10, 15
	Robot-controller (m)	5	10, 15
Mass (kg)		45	Transformer unit: 45
Power requirements		AC200-220V ±10%, 50/60Hz, 3ø	*Transformer unit AC380-415V ±10% 50/60Hz, 3ø or AC440-480V ±10% 50/60Hz, 3ø
		Class-D earth connection (Earth connection dedicated to robots), leakage current: Maximum 100mA	
Environmental condition	Ambient temperature (°C)	0 - 45	
	Relative humidity (%)	35 - 85 (no dew, nor frost allowed)	
Body color		Munsell 10GY9/1 equivalent	
Teach pendant		TFT color LCD display with touch-panel, E-Stop switch, teach lock switch, Enable switch	
Auxiliary storage unit		-	USB Memory
Interface		USB, Ethernet (100BASE-TX), RS-232C	

Teach pendant

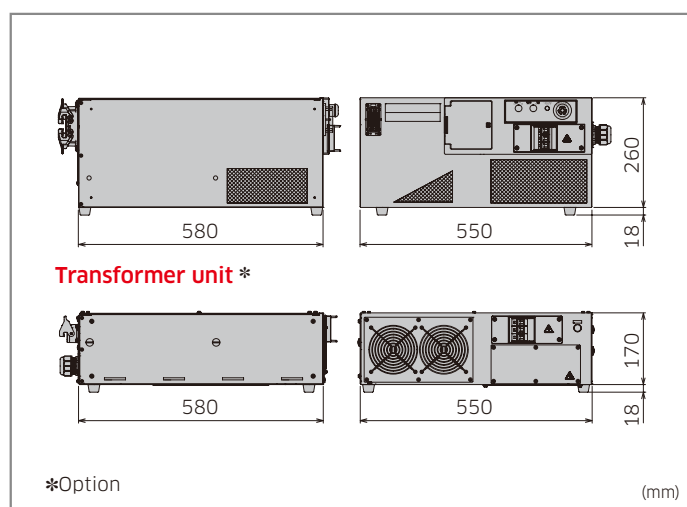
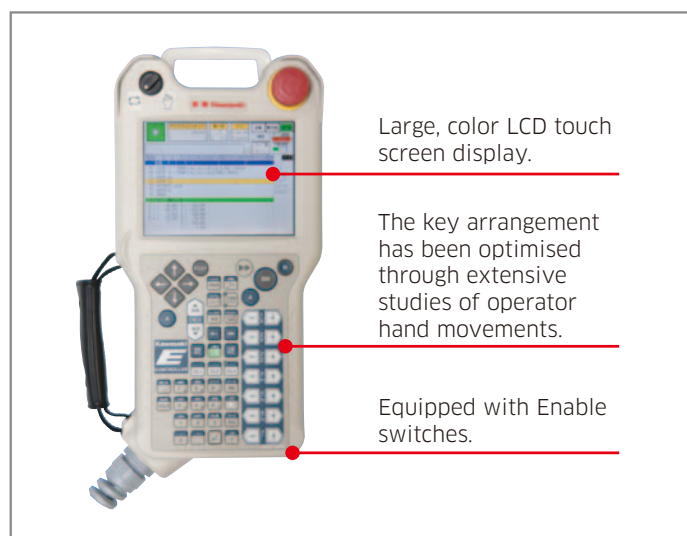

*Option

(mm)